

●ラジアルリード形(CE-04)自動挿入用テーピング仕様 / RADIAL LEAD (CE-04) TYPE TAPING FOR AUTOMATIC INSERTION

■ 5 mm ピッチテーピング
5 mm-pitch taping

記号 : T F
Symbol

Unit : mm

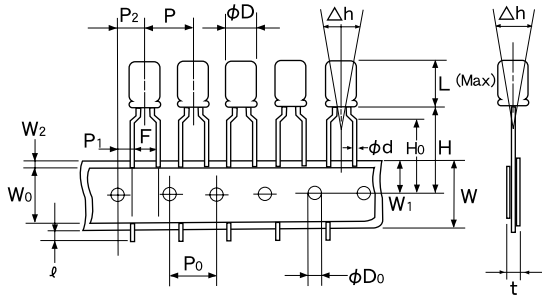

Sign	φ D	φ 5	φ 6.3	φ 8	φ 4, φ 5, φ 6.3, φ 8
φ d		0.5±0.05		0.6±0.05	0.45±0.05 0.45±0.05
L		12.0		12.5	8.0 6.0
P				12.7±1.0	
P ₀				12.7±0.2	
P ₁				3.85±0.5	
P ₂				6.35±1.0	
F				5.0±0.8	
W				18.0±0.5	
W ₀				6.0 Min.	
W ₁				9.0±0.5	
W ₂				1.5 Max.	
H		18.5±0.75		20.0±0.75	17.5±0.75
H ₀				16.0±0.5	
l				2.0 Max.	
φ D ₀				4.0±0.2	
Δh				0±1.0	
t				0.7±0.2	

■ リードストレートテーピング
Leads straight taping

記号 : T S
Symbol

Unit : mm

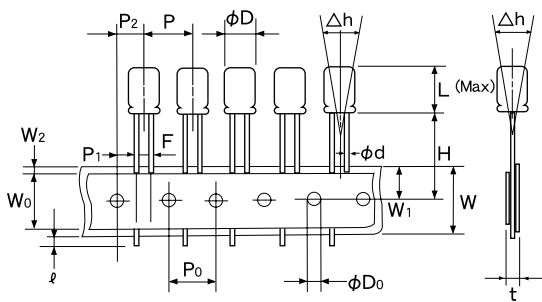

Sign	φ D	φ 5	φ 6.3	φ 8	φ 10	φ 12.5	φ 4, φ 5, φ 6.3	φ 8
φ d		0.5±0.05		0.6±0.05			0.45±0.05	
L		12.0		12.5	22.0	27.0	6.0 8.0 6.0 8.0	
P				12.7±1.0		15±1.0	12.7±1.0	
P ₀				12.7±0.2		15±0.2	12.7±0.2	
P ₁		5.2±0.5		4.6	3.85±0.5	5±0.5	5.2±0.5	4.6
P ₂			6.35±1.0			7.5±1.0	6.35±1.0	
F		2.5±0.5		3.5		5.0±0.8	2.5±0.5	3.5
W				18.0±0.5				
W ₀				6.0 Min.				
W ₁				9.0±0.5				
W ₂				1.5 Max.				
H		17.5±0.75		18.5±0.75		17.5±0.75		
l				2.0 Max.				
φ D ₀				4.0±0.2				
Δh				0±1.0				
t				0.7±0.2				

記号 : T W
Symbol

φ 12.5に適用 / Applies to φ 12.5

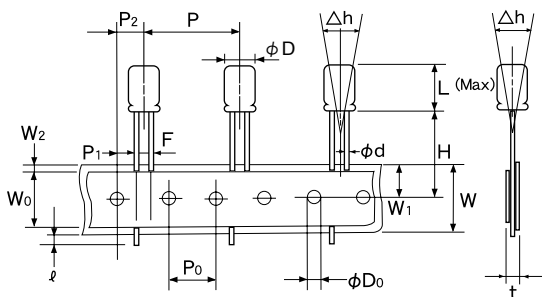

Sign	φ D	φ 12.5
φ d		0.6±0.05
L		27.0
P		25.4±1.0
P ₀		12.7±0.2
P ₁		3.8±0.5
P ₂		6.35±1.0
F		5.0±0.8
W		18.0±0.5
W ₀		6.0 Min.
W ₁		9.0±0.5
W ₂		1.5 Max.
H		18.5±0.75
l		2.0 Max.
φ D ₀		4.0±0.2
Δh		0±1.0
t		0.7±0.2

■ 包装方法 (つづら折)
PACKING WAY (AMMO PACK)

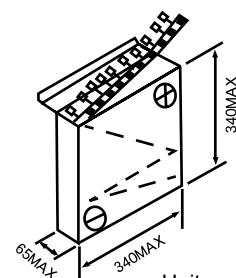

Unit : mm